

General Description

2-Way, 2 Position, Normally Open, Bi-Directional Poppet Valve. For additional information see Technical Tips on pages SV2-SV6.

Features

- Built-in thermal relief set at 36 Bar (500 PSI) above rated pressure
- One piece cartridge housing ensures internal concentricity
- Coil: Waterproof, hermetically sealed, requires no O’Rings; Coil is interchangeable with 02 and 06 series poppet valves; Symmetrical coil can be reversed without affecting performance.

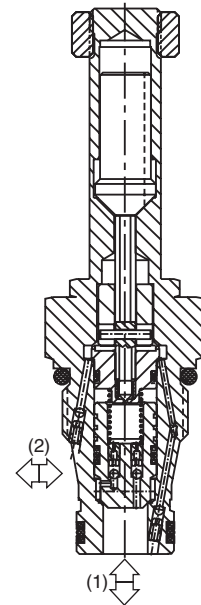
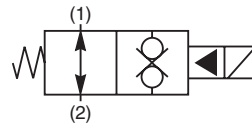
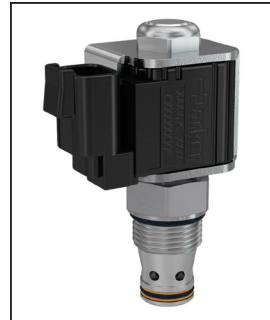

Specifications

Rated Flow	2 to 1 68 LPM (18 GPM) 1 to 2 46 LPM (12 GPM)
Maximum Inlet Pressure	86 350 Bar (5000 PSI)
Leakage at 150 SSU (32 cSt)	5 drops/min. (.33 cc/min.)
Minimum Operating Voltage	85% of rated voltage at 20°C (72°F).
Response Time	See Performance Curves
Cartridge Material	All parts steel. All operating parts hardened steel.
Operating Temp. Range/Seals	-34°C to +121°C (Nitrile) (-30°F to +250°F) -26°C to +204°C (Fluorocarbon) (-15°F to +400°F)
Fluid Compatibility/Viscosity	Mineral-based or synthetic with lubricating properties at viscosities of 45 to 2000 SSU (6 to 420 cSt)
Filtration	ISO 4404 18/16/13, SAE Class 4
Approx. Weight	.17 kg (.37 lbs.)
Cavity	2R (See BC Section for more details)

Performance Curves

Pressure Drop vs. Flow (Through cartridge only)

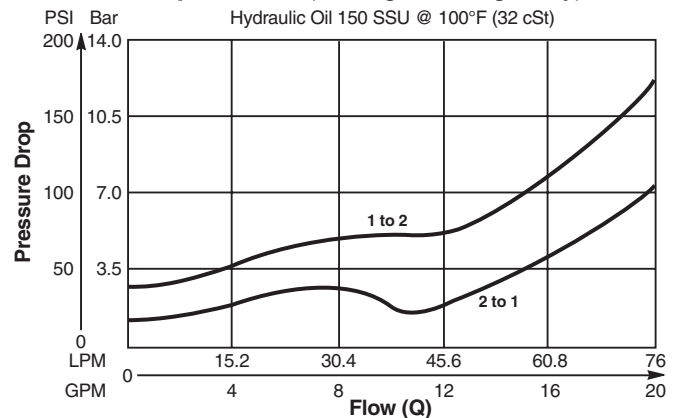

Response Time vs. Flow

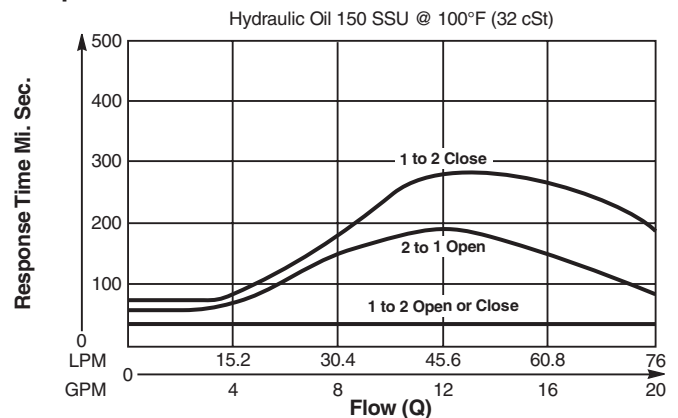

- CV**
Check Valves
- SH**
Shuttle Valves
- LM**
Load/Motor Controls
- FC**
Flow Controls
- PC**
Pressure Controls
- LE**
Logic Elements
- DC**
Directional Controls
- SV**
Solenoid Valves
- PV**
Proportional Valves
- CE**
Coils & Electronics
- BC**
Bodies & Cavities
- TD**
Technical Data

Dimensions Millimeters (Inches)

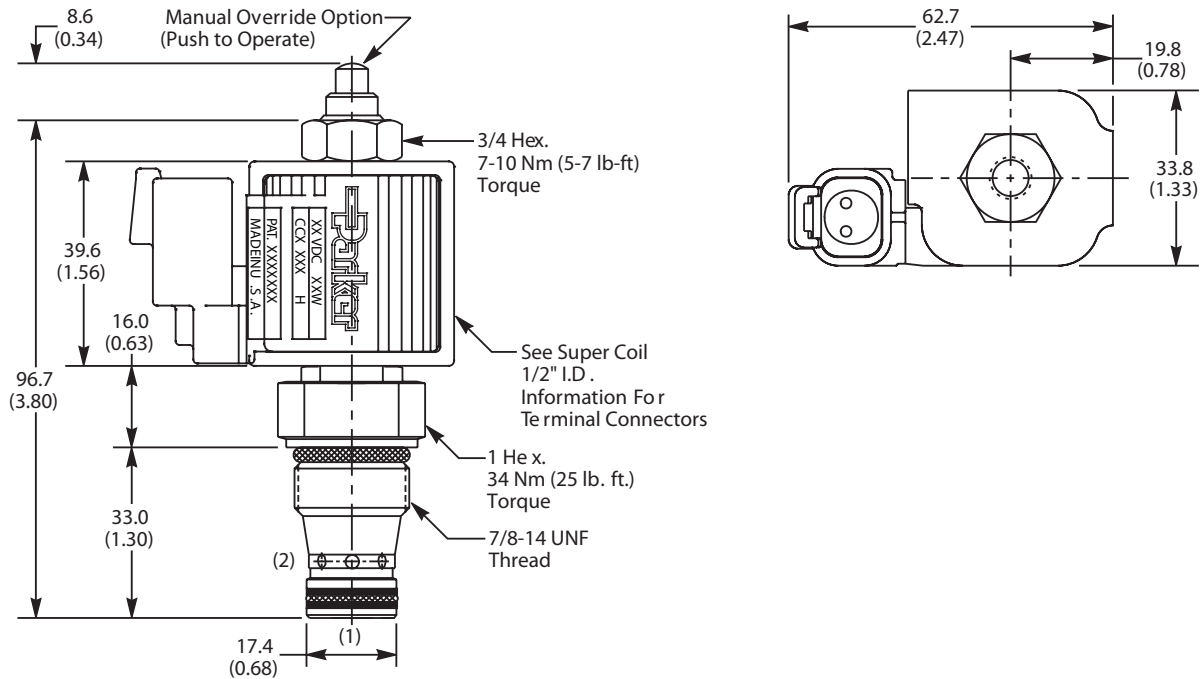

Ordering Information

GS04	86		0	N
10 Size Solenoid Valve	Style Normally Open	Override Option	Screen	Seals

Highlighted represents preferred options that offer the shortest lead times. Other options may be available, but at extended lead times.

Coil(s) sold separately. Please see section CE of this catalog, 1/2" Super-Coil (CC series), for ordering information.

Code	Style
86	High Pressure ('SP' Coil)

Code	Screen
0	None

Code	Override Options
0	None
1	Manual Override

Code	Seals
N	Nitrile

Order Bodies Separately
 See section BC

BW14	-	2	-	8T
14 size		2-Way Cavity		Port Size

Code	Port Size / Body Material
8T	SAE-8 / Steel (5000 PSI)

Kit	Part Number
Nitrile Seal	SK30113N-1
Fluorocarbon Seal	SK30113V-1

CV
Check Valves
SH
Shuttle Valves
LM
Load/Motor Controls
FC
Flow Controls
PC
Pressure Controls
LE
Logic Elements
DC
Directional Controls
SV
Solenoid Valves
PV
Proportional Valves
CE
Coils & Electronics
BC
Bodies & Cavities
TD
Technical Data